



FRONTIER
OIL CORPORATION

Frontier Refinery Inc.

Kevin Burke
V.P. and Refinery Manager
8/31/10



Frontier Refining Inc.

- Subsidiary of Frontier Oil Corporation out of Houston.
- Frontier Oil Corp. is a Refining and Wholesale marketing company
 - 187,000 bbl/day refining capacity
 - 52,000 bbl/day in Cheyenne, WY
 - 135,000 bbl/day in El Dorado, KS
 - Markets served
 - Rocky Mountain region
 - Plains states
 - Products Marketed
 - Diesel
 - Gasoline
 - Asphalt
 - LPG's



- Two Refineries
 - Cheyenne, WY 52,000 bbls/day
 - El Dorado, KS 135,000 bbls/day



FRONTIER
OIL CORPORATION

Cheyenne Operations

- Single train refinery
- Crude supply
 - Local producers via truck at the refinery
 - Pipeline from Guernsey (domestics and Canadian)
- Operating Philosophy – FLEXIBILITY
 - High Conversion Refinery
 - 85% heavy to 100% light sweet
 - 10-100 tons of sulfur production
 - Continually looking to optimize our crude slate
 - Looking for more economic crudes
 - Niche Crudes
 - Challenged Crudes
 - Always open for new opportunities



FRONTIER
OIL CORPORATION

Refinery Processing Units

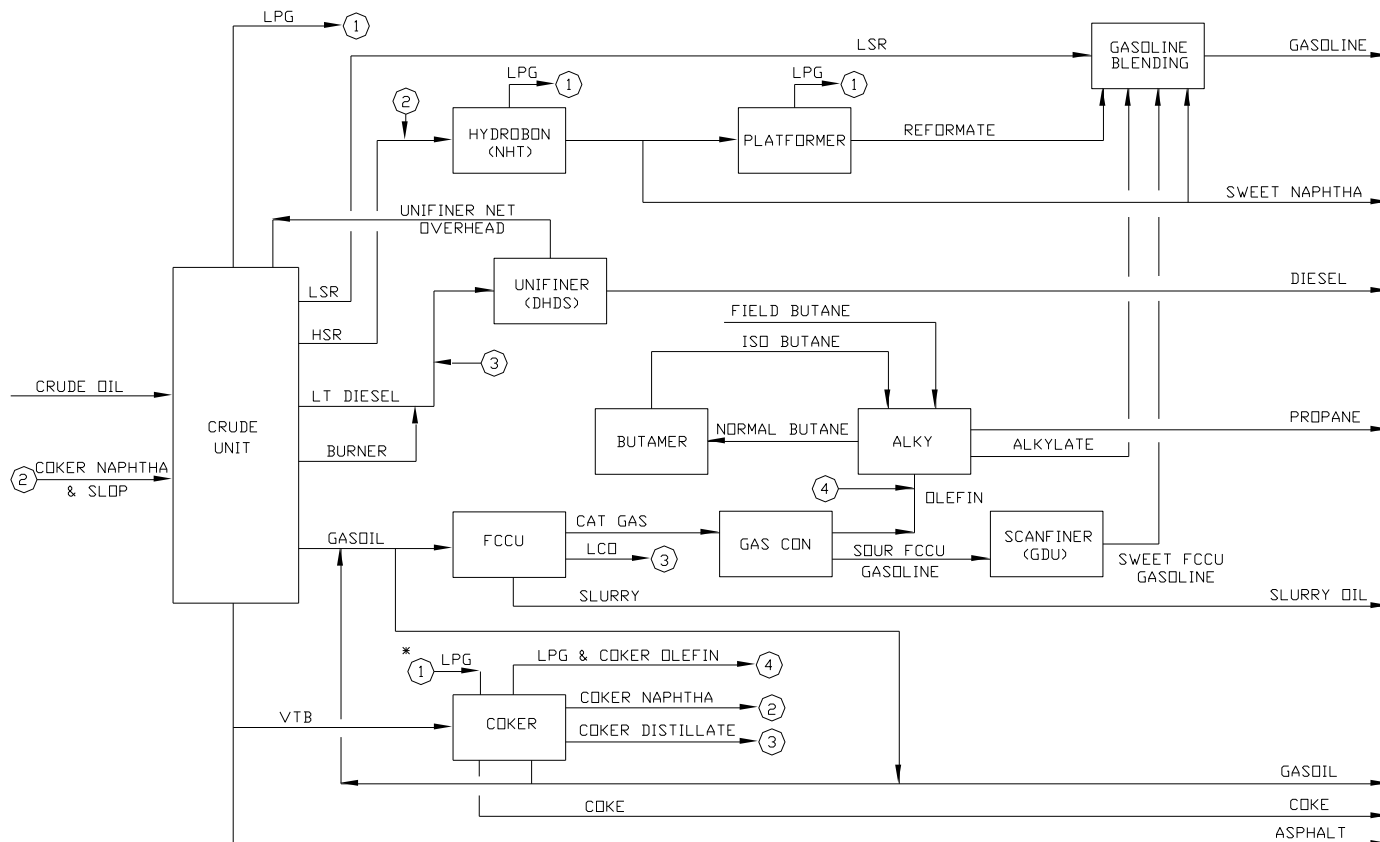



FRONTIER
OIL CORPORATION

Products and Markets Served

- Gasoline and Diesel to Denver via pipeline
- Diesel to some of the Local mines via truck
- Diesel and Gasoline off our local truck rack
- Diesel and Gasoline to Nebraska via pipeline
- Asphalt for local road projects
- Propane for local sales
- Coke for power generation via rail
- Sulfur for fertilizer production via rail



FRONTIER
OIL CORPORATION

Questions?